

# Optical Add Drop Multiplexer

# What is an OADM ?

Permits access to part of the traffic at an intermediate site  
Like the ADM functionality in SDH/SONET but at the optical level

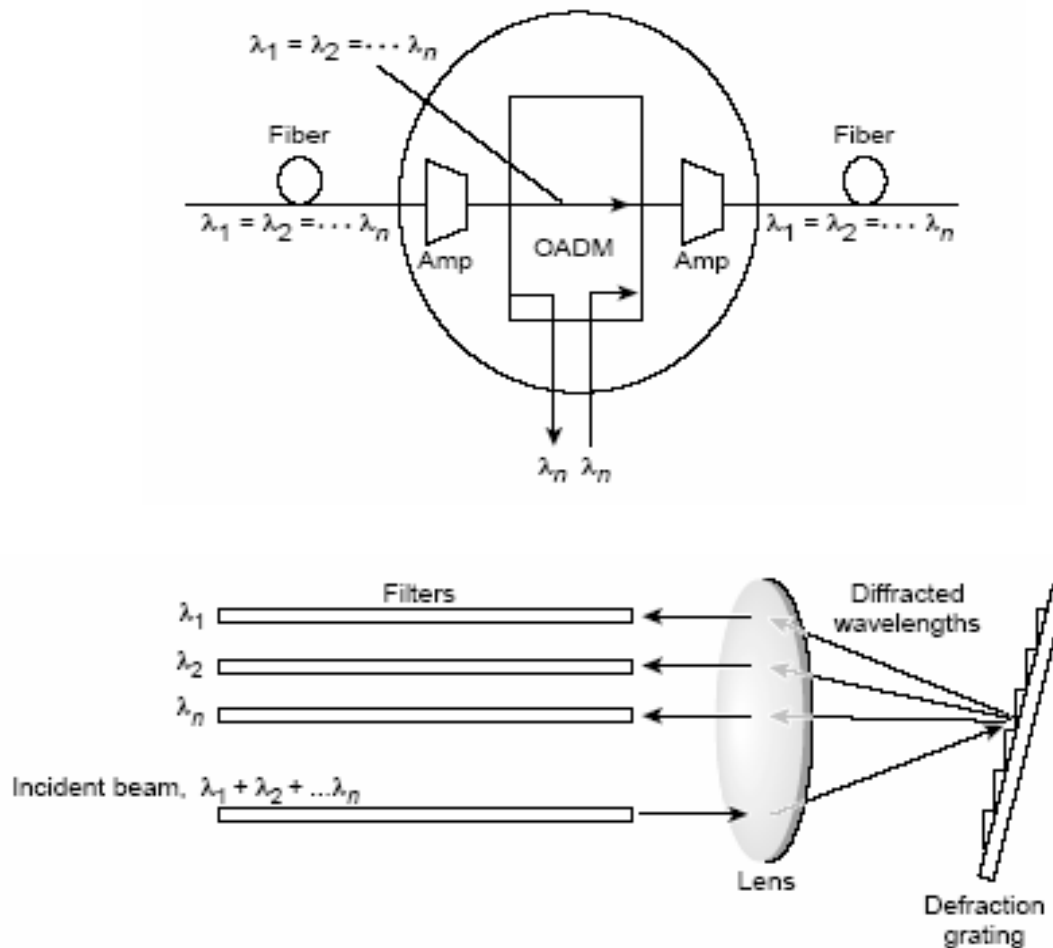

# OADM versus ROADM

## **OADM:**

Technology based on simple static filters that permits add/drop of predefined wavelength number.

Change between wavelengths has to be done locally and manually

## **ROADM:**

Technology based on the vision that any wavelength can be added/dropped from a remote location.

Some ROADM solutions uses static filters as well but the transition towards a fully dynamic solution is just around the corner.

A ROADM network element typically includes:

- Transponders
- ROADM Subsystem
- Optical Service Channel
- Optical Power Monitoring
- Amplifiers (Pre-Amp & Post-Amp)
- Dispersion Compensation Module

**It is a BIG unit !**

# Some different ROADM solutions

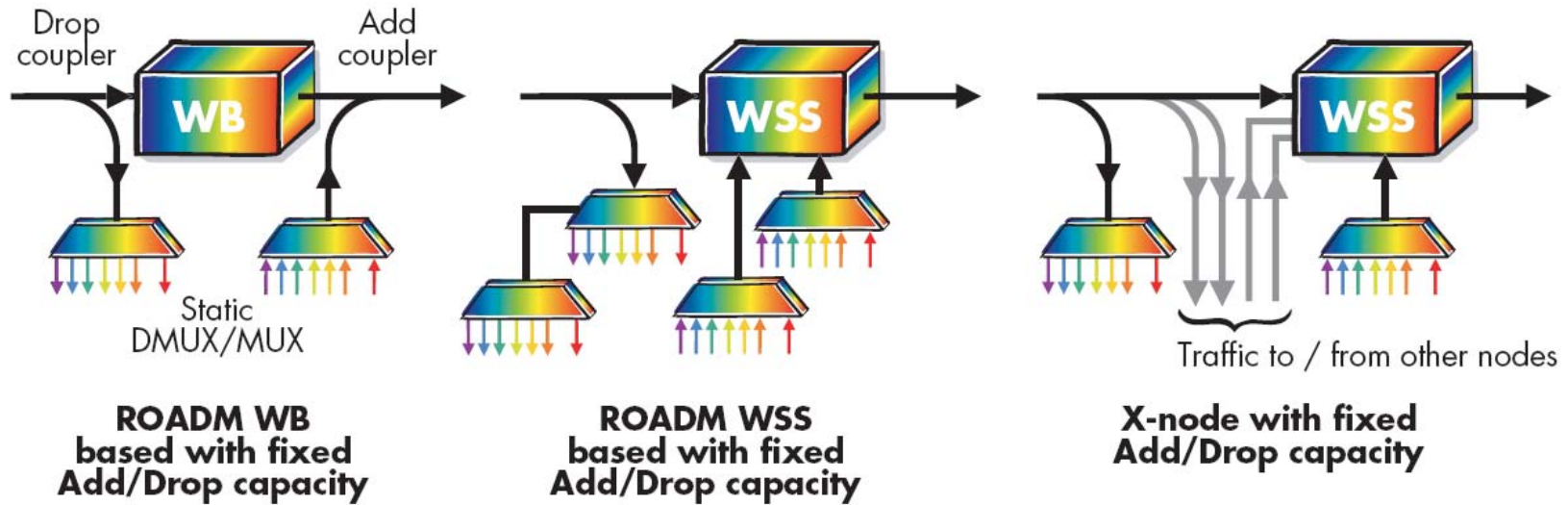

# Types of ROADMs

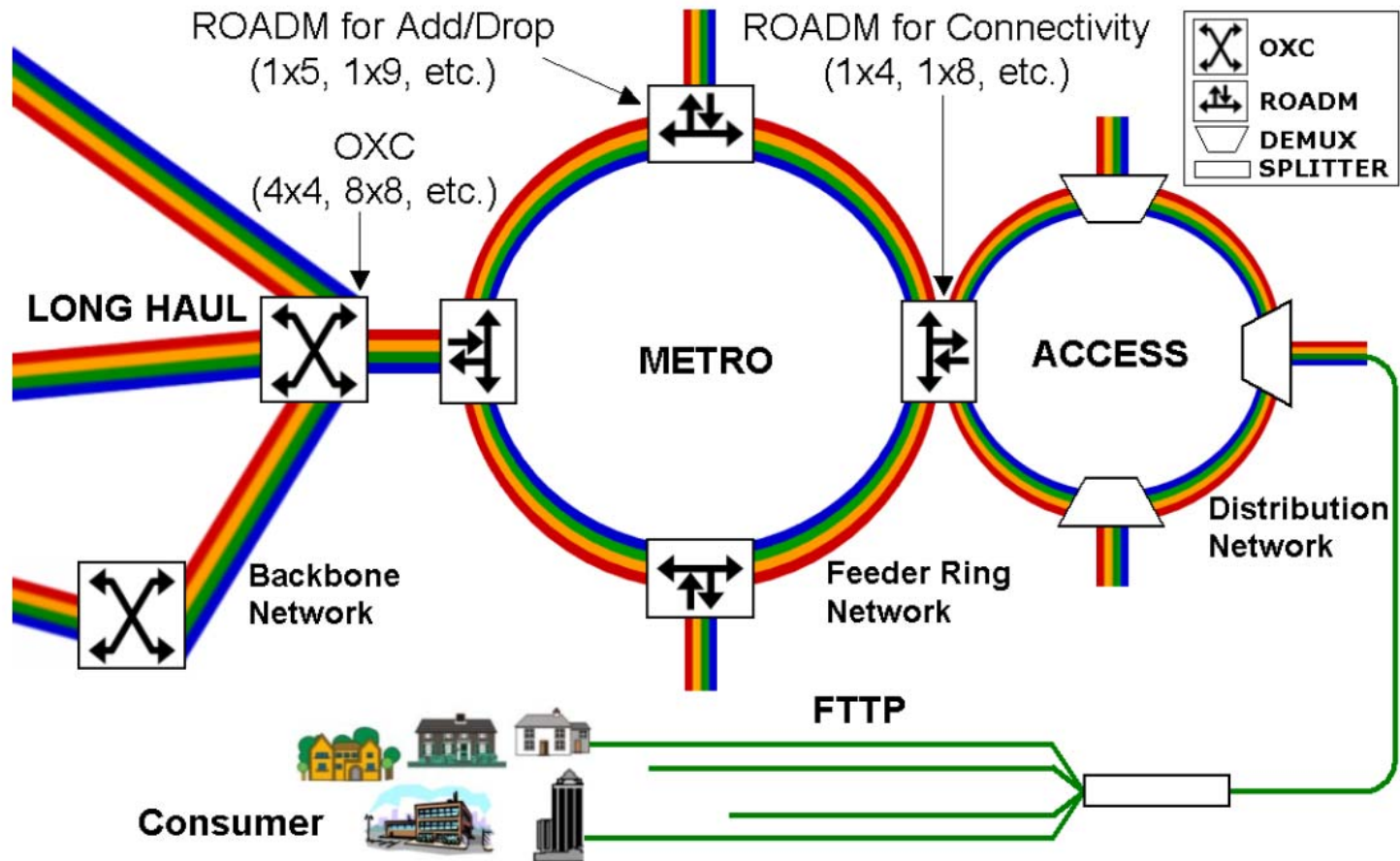

ROADM Type	Node Degree	Subsystems per Node	Add/Drop Channels	Colorless	Multiple $\lambda$ 's per Port
Type I ROADM	2	2 Subsystems per Degree 2 Node	N *	No	No
Type II ROADM	2	2 Subsystems per Degree 2 Node	M **	Yes	No
Wavelength Selective Switch (WSS)	N	N Subsystems per Degree N Node***	M-1 (1×M WSS) ****	Yes	Yes
Optical Cross-Connect (OXC)	N	1 Subsystem per Degree N Node	N/A (Mesh Connectivity only)	Yes	Yes

\* N: number of channels

\*\*  $M \leq N$

\*\*\* e.g., 4 1×4 WSS subsystems are needed for the interconnection of 2 fiber-pair rings

\*\*\*\* e.g., 1×5 WSS provides 1 express port and 4 Add/Drop ports

ROADM Type	Justification	Compatibility	Optical Components (Technology)
<b>Type I ROADM</b> Fixed ports	Stranded capacity reduction	Dual-use as DGE, DCE	<ul style="list-style-type: none"> <li>Wavelength Blocker (LCD or MEMS) + Fixed Filters (TFF)</li> <li>Demux + Small Switch Array + Mux (PLC)</li> </ul>
<b>Type II ROADM</b> Any $\lambda$ to any port	No manual intervention, monitor & control	Retain blocker, add tunable filters and tunable lasers, no impact to thru path; or all PLC solution, more cost-effective	<ul style="list-style-type: none"> <li>Wavelength Blocker (LCD or MEMS) + Tunable Filters/Lasers</li> <li>Demux + Small Switch Array + Mux + M×N Switches (PLC)</li> </ul>
<b>Wavelength Selective Switch (WSS)</b> Any multiple $\lambda$ 's to any port	Ring interconnect without OEO	Select locations only; interoperability with other nodes, same lasers	1×N Wavelength Selective Switch (LCD or LCoS or MEMS)
<b>Optical Cross-Connect (OXC)</b> Any multiple $\lambda$ 's from any port to any port	Mesh interconnect, mesh protection	Select locations only	<ul style="list-style-type: none"> <li>N×N Matrix Switch (PLC)</li> <li>N×N Wavelength Selective Switch (LCD or LCoS or MEMS)</li> </ul>

# Wavelength Blocker – Component level

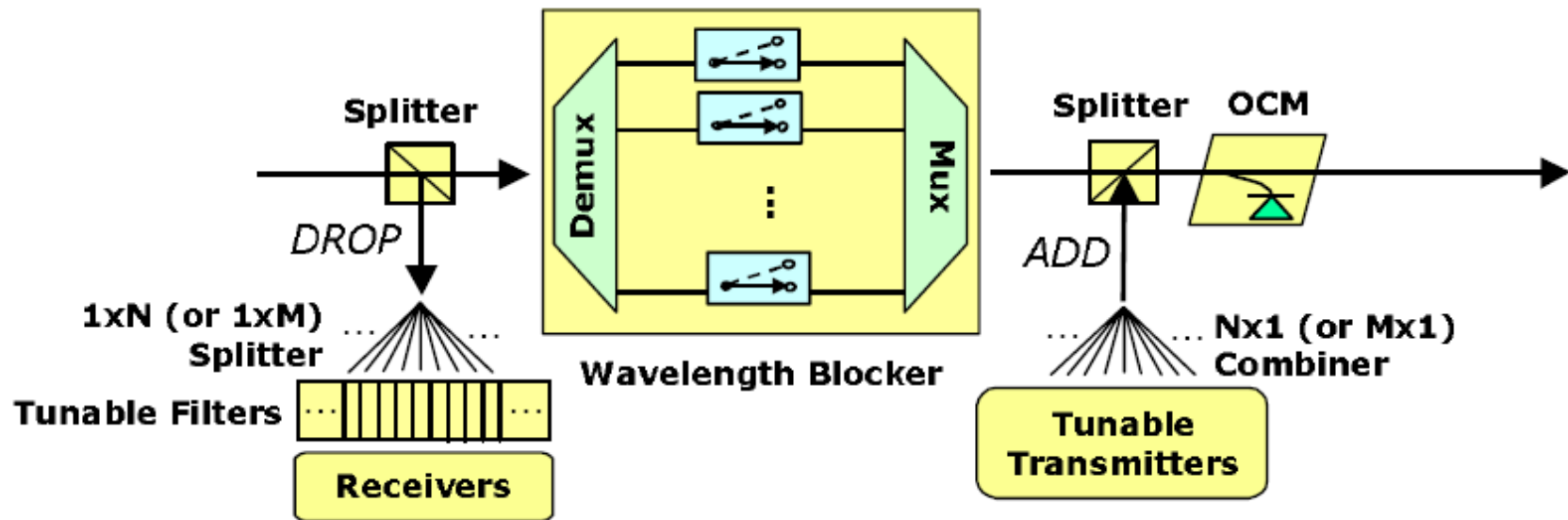

# WSS 1:9 - Component level

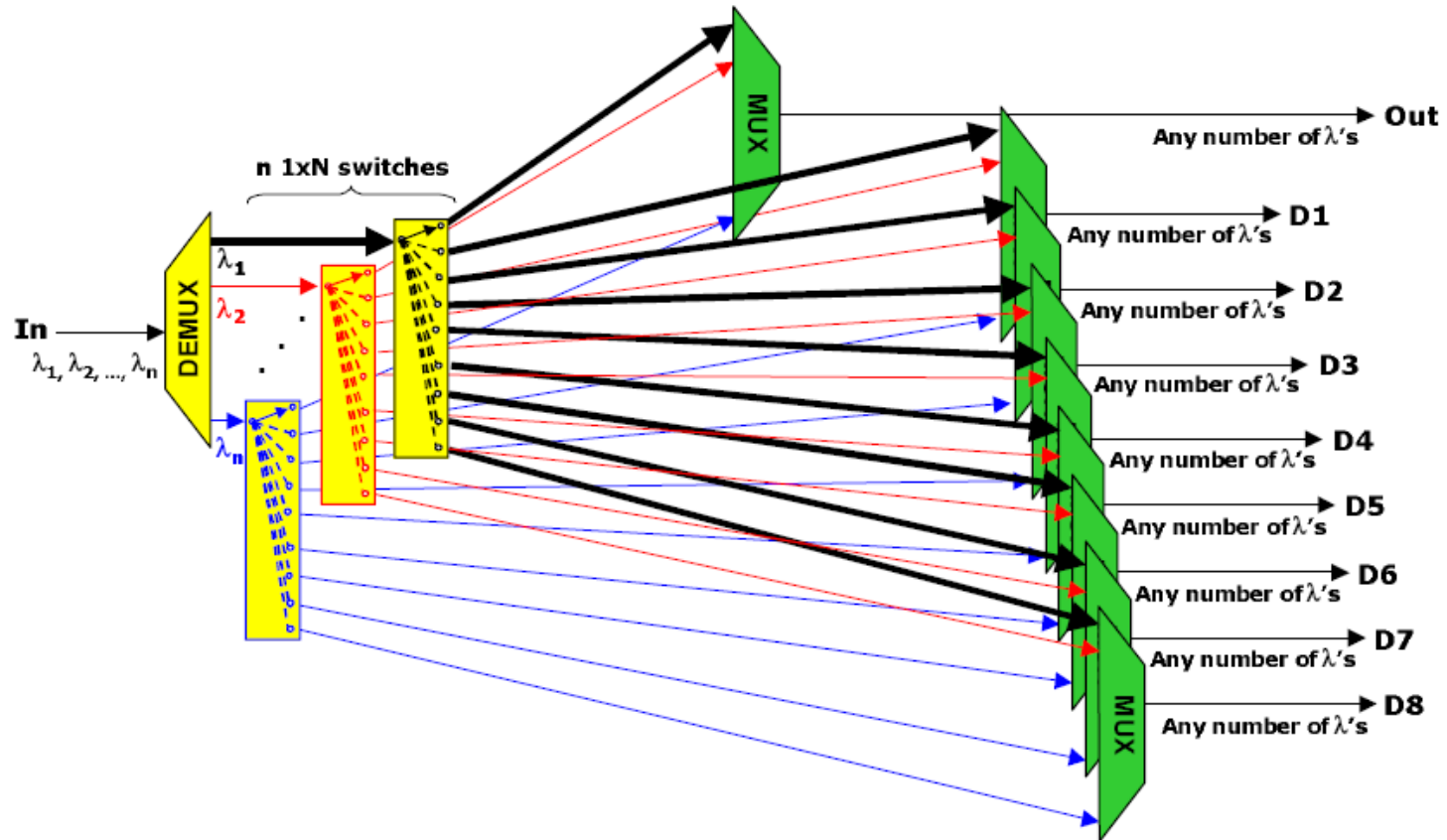

# WSS - Principal

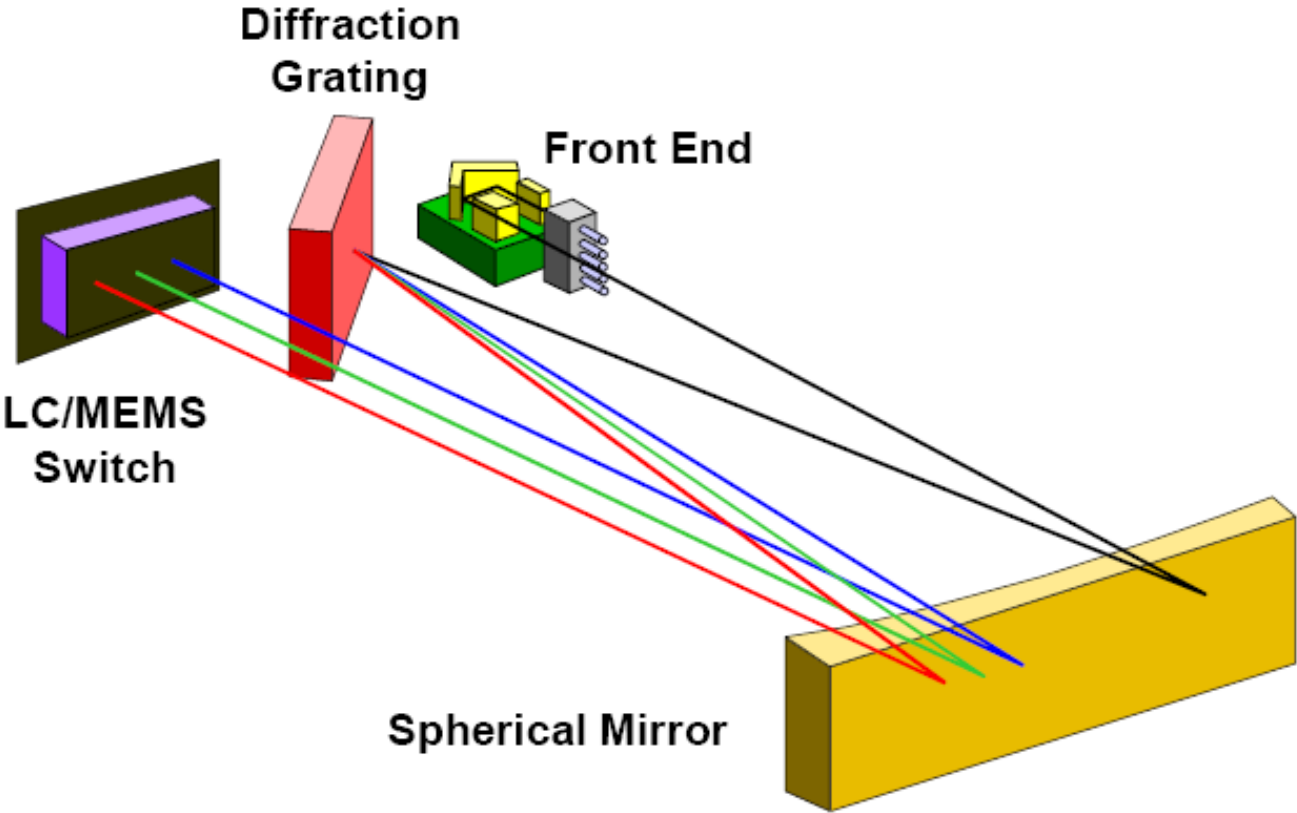

# Pros and cons of main ROADMs Solutions

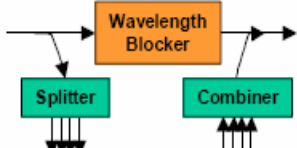
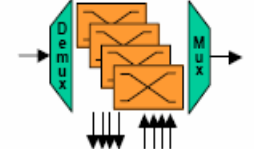
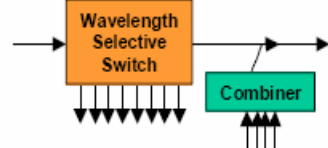
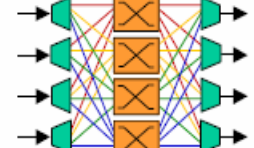
ROADM	Configuration	Pros	Cons
WB		First to be ready # A/D ports = N (all $\lambda$ 's)	Large size Expensive Fixed $\lambda$ /port Not degree upgradeable
SSA		Low cost Small size Simple software & hardware # A/D ports = N (all $\lambda$ 's)	Fixed $\lambda$ /port Not degree upgradeable
WSS		Any multiple $\lambda$ 's to any port Degree upgradeable	Expensive, extra \$ for 'Add' Complex software & hardware # A/D ports $M < N$ , not $\lambda$ upgradeable Large size
OXC		Any multiple $\lambda$ 's from any port to any port Degree upgradeable, $\lambda$ upgradeable Simple software & hardware Small size	Next generation for some carriers

- Wavelength Blocker (WB)
- Small Switch Array (SSA)
- Wavelength Selective Switch (WSS)
- Optical Cross-Connect (OXC)

# The Future Solutions

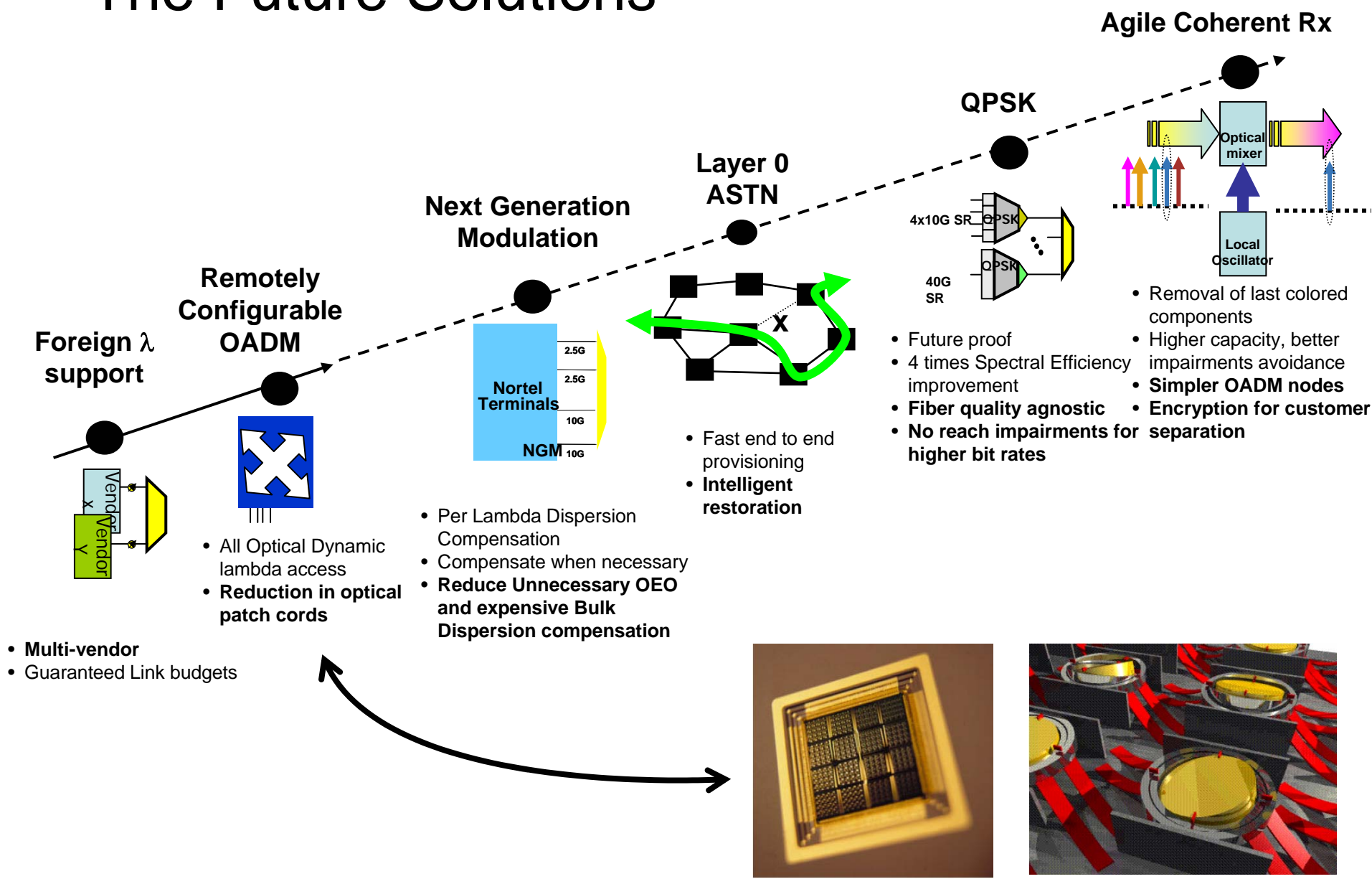

# ROADM - What is it good for ?

High degree of flexibility

Fast switching – Fast provisioning

Remote handling

Less O-E-O conversions

Future secure permits automated reconfigurable networks

Less people intervention – Higher uptime !

Cool new technology – Keeps you interested

# NORDUnet Target Network Solution based on 2D WSS technology 2-Branch

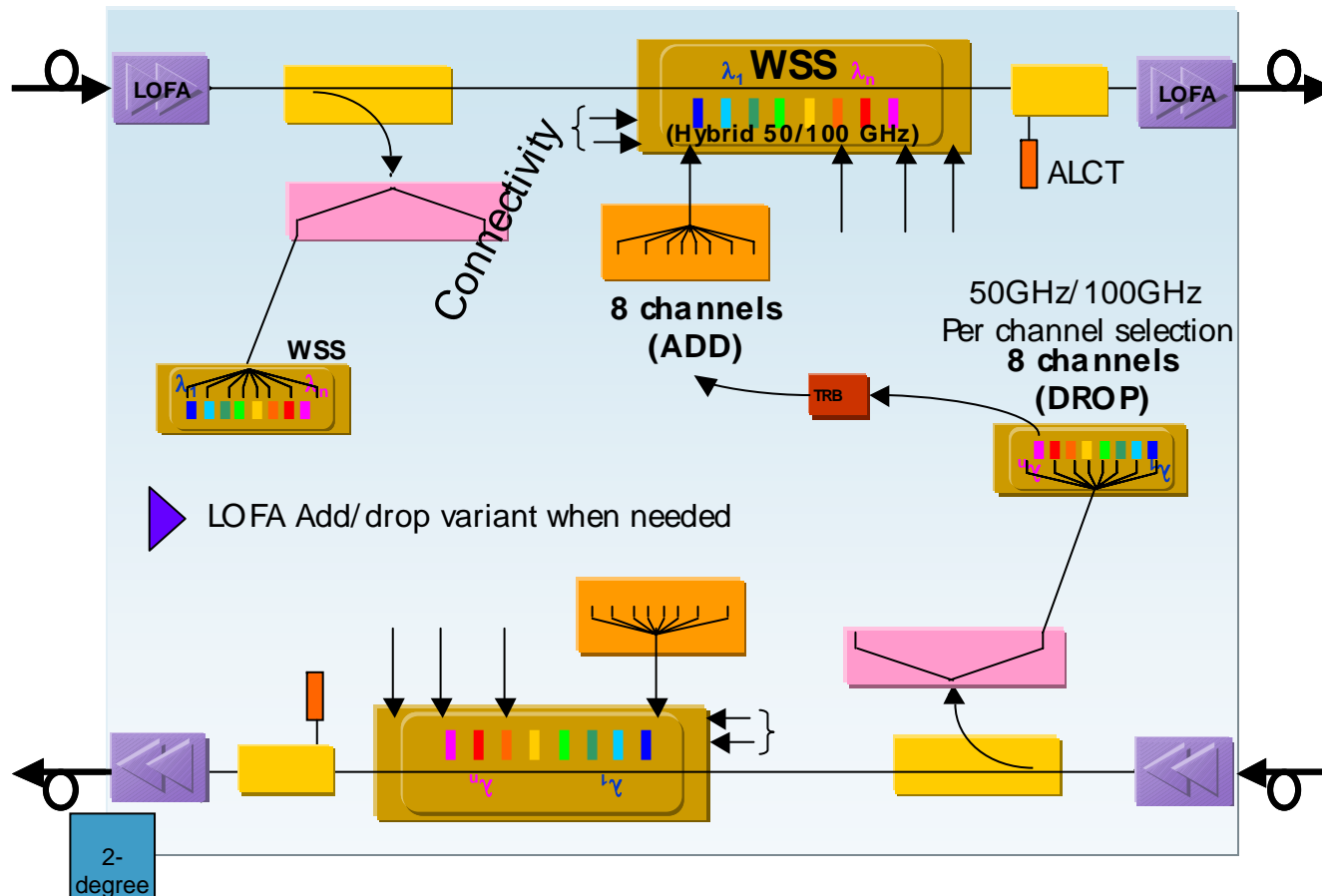

Take this picture back with you if nothing else 😊

